

BELÜFTUNGSTECHNIK
UMWELT- & VERFAHRENSTECHNIK
SERVICE & WARTUNG

OXYFLEX[®]-MS 70

MEMBRANE TUBE DIFFUSER



Supratec

GESELLSCHAFT FÜR UMWELT-
UND VERFAHRENSTECHNIK MBH

von-Drais-Straße 7
D-55469 Simmern/Hunsrück
Fon: +49 6761 9 65 09-00
Fax: +49 6761 9 65 09-01

e-mail: info@oxyflex.de
internet: www.supratec.cc

GENERAL INFORMATION

OXYFLEX®-MS70

MEMBRANE TUBE DIFFUSER

GENERAL INFORMATION

Supratec Gesellschaft für Umwelt- und Verfahrenstechnik mbH produces modern high efficient aeration systems, which are mainly used for oxygen transfer into biological waste water treatment.

These products can also be used for any kind of transfer of gases into liquids.

Membrane diffusers (plate, tubes and discs) with a plastic body are sold under the OXYFLEX® brand.

The unique characteristics of OXYFLEX® - MS membrane tube diffusers derive from its shape and the materials used.

DESIGN

The OXYFLEX®-MS70 membrane tube diffuser normally consists of two cylinders installed as pairs and is available in three sizes:

OXYFLEX®-MS70-1.0 (consisting of 2 x cylinders MS70-500 mm, Ø 70 mm)

OXYFLEX®-MS70-1.5 (consisting of 2 x cylinders MS70-750 mm, Ø 70 mm)

OXYFLEX®-MS70-2.0 (consisting of 2 x cylinders MS70-1000 mm, Ø 70 mm)

The body forms a polypropylene tube. The membrane is slipped over this tube and fastened by means of hose clamps.

MEMBRANE

The membrane is delivered in EPDM as standard.

Membranes made of Silicone and Polyurethane are also available.

The standard slot pattern is optimized to achieve fine bubble aeration with maximum oxygen transfer efficiency.

The characteristics can be adapted for special applications.

CHARACTERISTICS

OXYFLEX®-MS70 membrane tube diffusers generally produce fine gas bubbles of a diameter <2 mm and can be operated intermittently. They are highly resistant to soiling.

OXYFLEX®-MS70 membrane tube diffusers are suitable for installation on stainless steel and plastic pipes and for all forms of tanks, but are particularly suitable for medium to large tanks. OXYFLEX®-MS70 membrane tube diffusers have a proven track record in municipal and industrial plants worldwide.

PERFORMANCE

OXYFLEX®-MS70 membrane tube diffusers have an operating range for EPDM membranes of 0 - 12 Nm³/h per running metre. The design specific load should be 2 - 9 Nm³/h per running metre.

The operating range for silicone and TPU membranes is 0 - 9 Nm³/h per running metre. The design air flow in this case should be 2 - 7 Nm³/h per running metre.

OXYFLEX®-MS70 membrane tube diffusers can reach a specific standard oxygen transfer efficiency up to and in excess of 25 gO₂/(Nm³ • m) in clean water subject to favourable coverage and water depth.

COMBINATION

OXYFLEX®-MS70 membrane tube diffusers can be combined with PERMOX® or Brandol® ceramic tube diffusers.

VARIATIONS

OXYFLEX®-MS70 membrane tube diffusers membrane tube diffusers are also available as medium to coarse bubble diffusers.

I L L U S T R A T I O N

OXYFLEX[®] - MS70 INSTALLATION

CHARACTERISTICS

OXYFLEX[®]-MS70 membrane tube diffusers can be mounted onto round or rectangular distribution pipes (connectors and clamp saddles are available for different tube sizes).

They have a strong and solid body made of polypropylene on which a perforated membrane (e.g. EPDM) sits. The membrane is fixed with two stainless steel hose clamps.

INSTALLATION PREPARATION

Before installing the OXYFLEX[®]-MS70 membrane tube diffuser, make sure that the pipework is clean. All drilling chippings, dirt, etc. must be removed when the fans are switched on. Otherwise it is carried into the diffusers, where it can cause significant impairment/damage to the diffusers.

LEVELLING

Prior to installation of the diffuser, the pipe system must be levelled to a maximum of ± 10 mm.

INSTALLATION ON SQUARE STAINLESS STEEL PIPING

Installation with double nipple

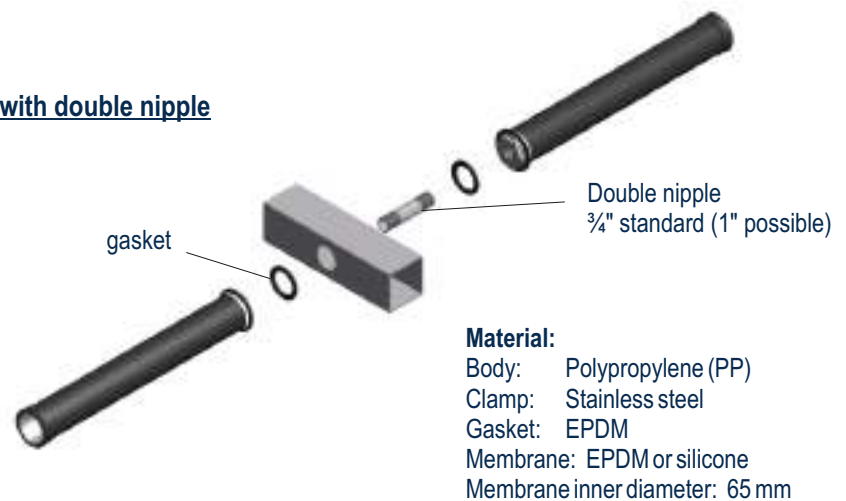

Top view

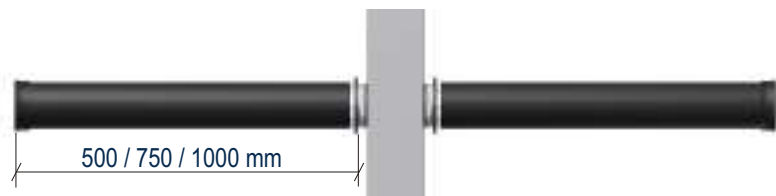

Details

With centring

for standard bore: 40 mm
 (also available for bores of 36 - 45 mm)



Without centring

For bore diameters of 27- 35 mm

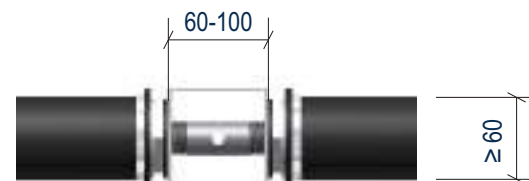

Tightening torque 45 Nm

INSTALLATION DESCRIPTION

To begin with, the short thread end of the connector is screwed by hand to one of the two suspension tubes. It is then installed and screwed to the second tube as shown in the drawing.

The diffuser cylinders are tightened using a fork wrench (width across flats 55).

I L L U S T R A T I O N

OXYFLEX[®] - MS70 INSTALLATION

KING - SIZE
WITH BOLTS

King Size Installation



Top View

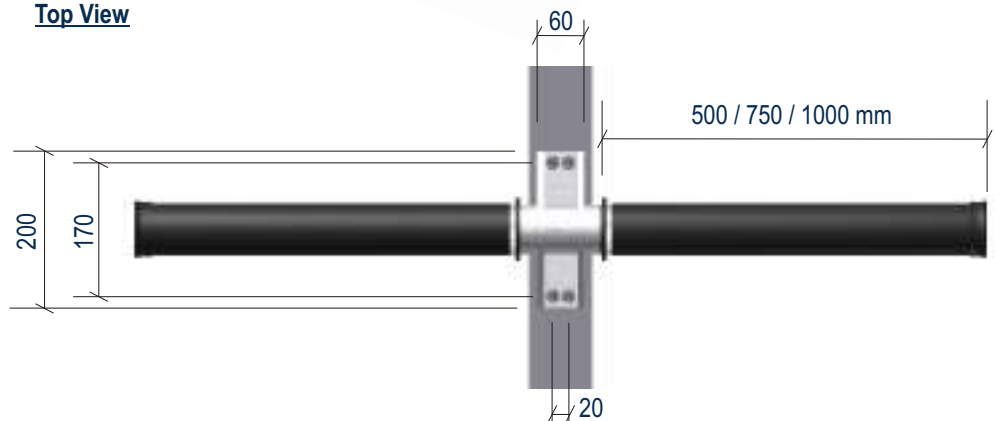

Detail

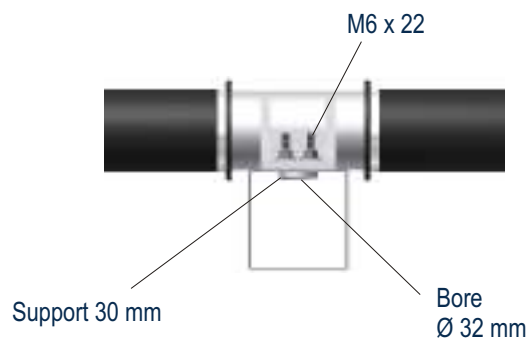

Tightening torque: 8 Nm

INSTALLATION
WITH BOLTS

The diffuser pair is placed onto the square pipe from above and screwed from above by means of a welded-on bolt with washers and M6 x 22 nuts.

I L L U S T R A T I O N

OXYFLEX® - MS70 INSTALLATION

INSTALLATION ON ROUND PIPE

Installation with clamp saddles

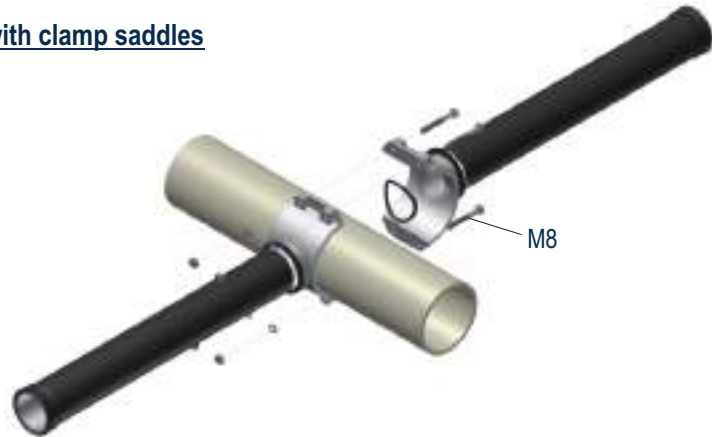

Top View



Detail



Clamp saddles available for
the following pipe outer diameter
75 mm (DN65/76.1 mm)
90 mm (DN80/88.9 mm)
110 mm (DN100/114.3 mm)

Anzugsdrehmoment: 9 Nm

INSTALLATION DESCRIPTION

First check whether the gaskets in both half shells are correctly inserted. The hose diffusers are then fastened in pairs to the half shells on the round pipe, but the 4 screws (M8 x 55 mm) are not yet fully tightened. Beforehand, care must be taken to ensure the exact horizontal alignment of the two diffuser sides. Once the alignment is complete, the 4 screws are fully tightened. Using a torque wrench (width across flats 13).

CONNECTION WITH MALE THREAD

Direct installation with 1" male thread



Tightening torque: 45 Nm

INSTALLATION DESCRIPTION

The OXYFLEX®-MS70 membrane tube diffuser with a 1" male thread is screwed directly into an available 1" connection thread. A flat gasket is inserted onto the head of the diffuser as shown in the drawing. The OXYFLEX®-MS70 membrane tube diffuser is then installed by screwing the tube with the aid of a fork wrench (width across flats 55).

GRAPHS OF OXYGEN PRESSURE

OXYFLEX®-MS70

MEMBRANE TUBE DIFFUSER

OXYFLEX®-MS70 membrane tube diffusers are highly efficient diffusers that are mainly used to supply oxygen to biological waste water treatment plants.

In addition to the requirements of the technical process, the key criteria for selecting suitable fine-bubble aeration technology are the performance features of a product. This offers a good compromise between capital investment costs, operating costs and operating range. The graph below shows sample measurements from an oxygen transfer test. The values were measured in a rectangular tank with a water depth of 5.75 m, an immersion depth of the diffuser of 5.45 m at a coverage density of 10.8%.

The values cannot be applied to other systems as the deviation can amount to $\pm 25\%$ and more.

Supratec is happy to provide a data sheets for specific applications on request.

No warranty claims can be derived from the graph!

**Specific standard oxygen transfer SSOTR and pressure loss
for the OXYFLEX®-MS70 membrane tube diffuser**

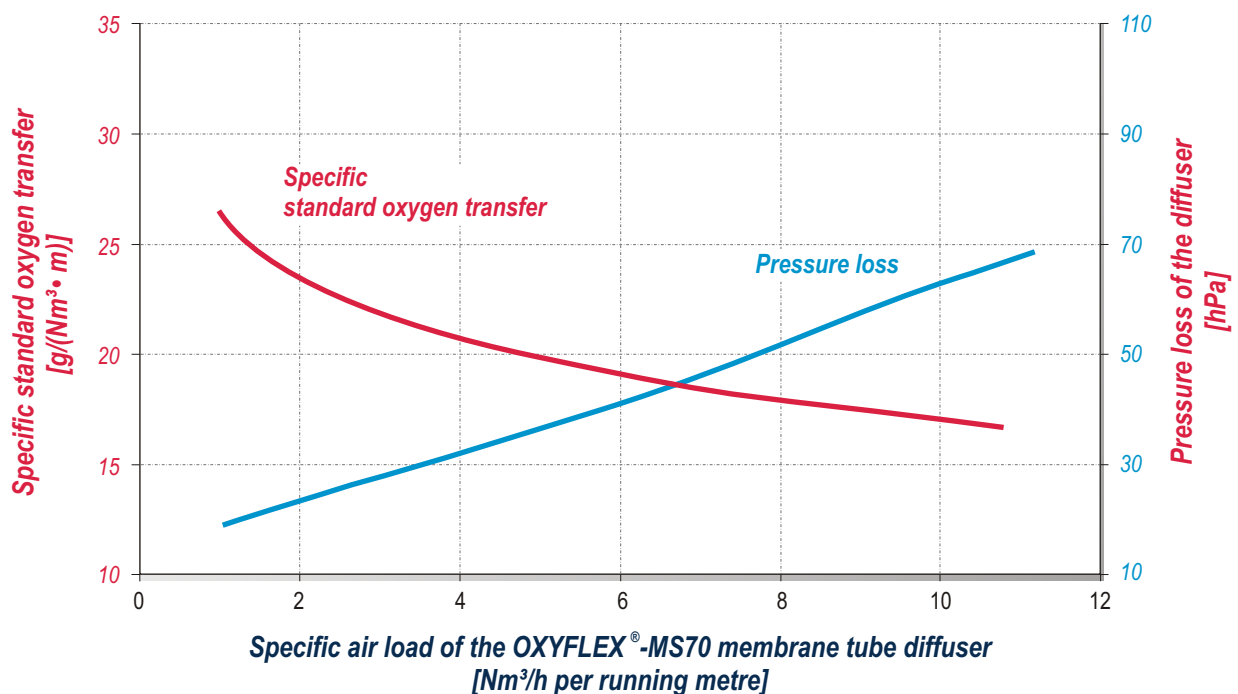

OPERATING INSTRUCTIONS

OXYFLEX®-MS70

MEMBRANE TUBE DIFFUSER

FUNKTION AND LEAKAGE CHECK

After the OXYFLEX®-MS70 membrane plate diffusers have been installed, a function and leakage check must be performed.

Fill the tank with clean water up to a maximum of 10 cm above the diffuser top edge and apply air to the diffusers (6 Nm³/h per running metre).

Then check and document the leak-tightness and function of the diffusers.

RUNNING IN THE DIFFUSER

Once the function and leakage check have been performed, the OXYFLEX®-MS70 membrane tube diffusers must be operated continuously for at least 60 hours with a specific air load of at least 8 Nm³/h per running metre.

The water level must be increased to at least 100 cm above the top edge of the diffuser as quickly as possible.

Important:

- The diffusers must not be deactivated
- The air volume must not exceed 11 Nm³/h per running metre

BUBBLE PATTERN

New membranes may exhibit inconsistent gaseous transfer behaviour to begin with.

For this reason, we do not recommend evaluating the bubble pattern before the diffusers have been run-in as described above.

To evaluate the bubble pattern, the diffusers are run from the maximum to the minimum air load.

- Consistent bubble distribution by the diffusers (bubble pattern check) must be carried out by filling the tank with at least 60 - 100 cm of water above the surface of the diffuser and an air flow of at least 6 Nm³/h per running metre.
- The uniformity of aeration at a minimum air load can only be checked at a water temperature greater than 10°C.

OXYGEN TRANSFER TEST

Prior to carrying out an oxygen transfer test as proof of the efficiency of the OXYFLEX®-MS70 membrane tube diffuser, the above steps must have been completed.

The oxygen transfer test can be carried out in accordance with recognised regulations (e.g. DWA 209/DIN EN 12255-15) based on the clean water or waste water method.

Warranty values must be rigorously adhered to. A calibrated and exact measurement of the air volume is required.

COMMISSIONING

If commissioning is delayed, make sure that the diffusers are sufficiently covered by water (at least 100 cm) to protect the OXYFLEX®-MS70 membrane tube diffuser against excessive sunlight and/or frost.

MAINTENANCE - INSTRUCTIONS

OXYFLEX®-MS70

MEMBRANE TUBE DIFFUSER

MAINTENANCE

OXYFLEX®-MS70 membrane tube diffusers require minimal maintenance. Normally, all that's required is 10 to 15 minutes operation at maximum air-flow per day, where each individual OXYFLEX®-MS70 membrane tube diffuser is subjected to an airflow of at least 10 Nm³ /h per running metre.

In order to do this, it may be sufficient to shut-off individual strings.

This can also be done to remove deposits after longer periods of inactivity and longer-term operation at low specific air loads.

The OXYFLEX®-MS70 membrane tube diffusers must be visually checked at least once annually. During this check, pay particular attention to possible deposits. If deposits are present, these must be carefully removed.

MONITORING

The bubble pattern must be checked on a daily basis. The pressure loss must be checked and documented every month. Significant changes of the bubble pattern and/or pressure loss must be reported to Supratec immediately. Particularly in the case of plants that are operated intermittently, there is a risk that damaged OXYFLEX®-MS70 membrane tube diffusers can allow the ingress of live sludge into the entire pipework system. This will adversely affect the function and service life of all OXYFLEX®-MS70 membrane tube diffusers.

CLEANING

In general, dirt and contamination (deposits, sludge, plaque, etc.) on the membranes can easily be removed. Depending on the type and composition of the dirt, one of the following methods or a combination of several methods might be required. In each case, the compatibility and successful result of each method must be checked on an individual membrane.

• Manually: Cleaning with water and a soft brush.

• Alkaline solutions: Alkaline cleaning agents can normally be used in diluted form.

• Acids: In some cases, it might be necessary to add weak acids to the compressed air (see below) or to clean the membranes with diluted acids.

Cleaning instructions are available from Supratec

ACID DOSING

If necessary, dilute acids (e.g. 85 % formic acid for EPDM membranes) may be added to the compressed air. Under certain circumstances, this can result in longer cleaning intervals and lower pressure loss of the membranes.

Information about acid dosing is available from Supratec.

STORAGE

Store the diffusers in their packaging in a dry, ventilated room with uniform temperature distribution. DIN 7716 provisions must be observed.